

## STANDARD EQUIPMENT Includes:

- ? CO<sub>2</sub>/N<sub>2</sub> Inflation System w/ Twin Oversized Buoyancy Tubes
- ? Three (3) Position (Closed, Sail & Convertible) Heavy Duty, Dual Color Canopy w/ Cinch Strap
- ? Sure-Seal™ Closures w/ #10 YKK Heavy Duty Zippering
- ? Dual Main Zipper w/ Ventilation Tie Backs
- ? Single Arch, Auto Inflatable, Canopy Support System
- ? Oversized Front Boarding Entry w/ 4 Rung Boarding Ladder
- ? Interior Assist Ladder w/ Quick-Release Fittings
- ? Three (3) Bowed Boarding Assist Handles
- ? Front Boarding Stirrups
- ? Combination Foul Weather Observation Port Hole & Water Collection System w/ Sure-Seal™ Closures
- ? Water Activated Interior/Exterior Survivor Locator Lights
- ? Quick-Grab™ Pelican® Magnum MityLite™ Flashlight On Arch
- ? Auto-Deploying Hemispherical Drogue (Sea-Anchor) w/ 100' Line & Dual Anti-Foul Swivels
- ? 100' Floating Heaving Trailing Line w/ Buoyant Throwing Handle
- ? 50' Painter Line w/ Quick-Release Fittings
- ? Heavy Duty EZGrip™ Righting Line w/ Contrasting Bowed Hand Grips
- ? Unidirectional Retro/Radar Reflective Segment Across Arch
- ? Unidirectional Retro Reflective Segments Under Life Raft & On Canopy
- ? Cape Horn Ballast System™
- ? 1" Exterior Lifelines & Interior Grasp Lines
- ? Pressure Relief Valves
- ? Topping-Up Valves
- ? Urethane Valise
- ? Basic Offshore Survival Equipment Package As Listed Below

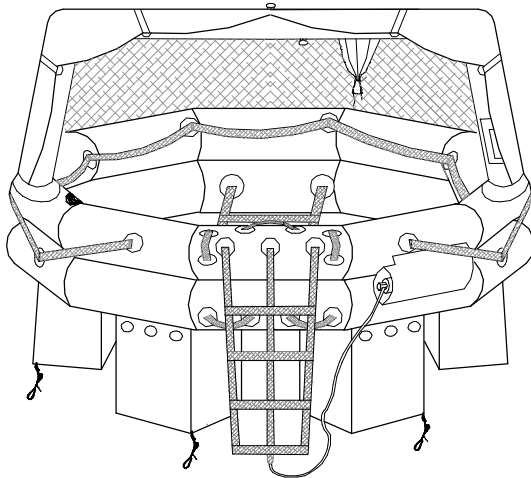

NOT TO SCALE

Front View  
Closed Canopy

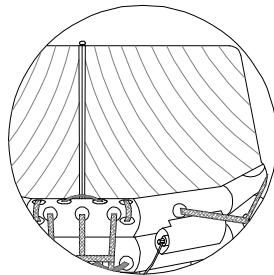

WINSLOW Model #	Rated Capacity	Dimensions			Weight
		H	x	W x L	
40SLO	4	8"	x	17" x 35"	41 lbs
60SLO	6	8"	x	17" x 36"	49 lbs
80SLO	8	8.5"	x	18" x 36"	57 lbs
100SLO	10	9"	x	18" x 36"	66 lbs
120SLO	12	10"	x	19" x 36"	77 lbs

Weights Are Approximate

## Basic Offshore Survival Equipment Package Includes:

- ✂ Manual Inflation Pump – Spring Loaded Return w/ Adapter
- ✂ Repair Kit (Includes: Repair Tape, Repair Clamp (3") & 2 PRV Plugs w/ Tether)
- ✂ Collapsible Bailer Bucket w/ Handle
- ✂ Sponges
- ✂ Magnetic Compass
- ✂ Paddles w/ Retro Reflective Segments
- ✂ Signal Mirror (3" x 5")
- ✂ USCG/SOLAS Whistle
- ✂ Extended Life Flashlight (Sealed Case)
- ✂ Spare Alkaline Batteries & Spare Xenon Bulb Assembly for Magnum MityLite™
- ✂ USCG Aerial Meteor Flares
- ✂ USCG Hand Held Locator Flares
- ✂ Orange Smoke Signal
- ✂ Rescue Streamer™ Ribbon (6" x 25')
- ✂ Retaining Line (75')
- ✂ Sea Dye Marker
- ? Water Rations (16oz./Person)
- ? Food Ration Bars (1000 Cal./Person)
- ? Anti-Seasickness Tablets (6/Person)
- ? Sun Block (Minimum 30SPF)
- ✂ First Aid Kit
- ✂ Fishing Kit
- ? Nitrile Gloves (1 Pair/2 Person)
- ✂ Raft Knife
- ✂ Utility Knife (SS Lockback)
- ✂ Drinking Cup
- ✂ Bible
- ✂ Water Storage Bag
- ✂ Survival Manual
- ✂ Oral Inflation Tube

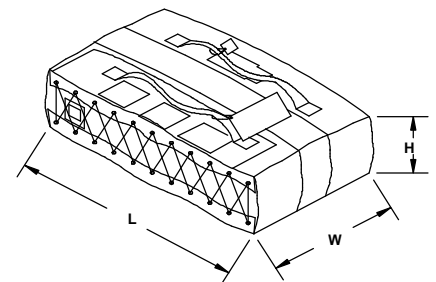

NOT TO SCALE

(800) 838-3012 ~ Fax (941) 613-6677  
[www.winslowliferaft.com](http://www.winslowliferaft.com) ~ [rafts@winslowliferaft.com](mailto:rafts@winslowliferaft.com)

## Available Optional Equipment

Fixed Life Raft Equipment	
	Canopy - HD Tripod Arch Tube
	Canopy Mounted Strobe
	Lifelines/Grasplines - Heavy Duty 2" - Upgrade
	StoreSafe™ Dry Survival Gear Stow Pockets (5)
	Boarding Platform
Stability Aids	
	Righting Ladder - w/ Contrasting Bowed Rungs -Upgrade
Life Raft Pack Options	
	Canister & Cradle Assembly, UV Inhibiting
	Canister & Railmount Assembly, UV Inhibiting
	Canister - Hydrostatic Release
	Valise - Additional Handles (Set of Two)
	Valise Custom Dimensional Packing
	WINSLOW® Pelican® Pac™ 4 or 6 Person Offshore (P/N 430)
	WINSLOW® Pelican® Pac™ SS Cradle (Coastal/Offshore)
	Ultima Wrap™ Vacuum Seal (3 yr. Protection)
Electronic Devices	
	406 EPIRB
	406 GPIRB
Repair Equipment	
	Repair Clamp, Mil Spec - 3" (Additional)
	Repair Clamp, Mil Spec - 5"

Signaling Devices	
	Cyalume Stick (Red)
	Flare - Parachute USCG/SOLAS
	Flare - Red Hand Held Locator - USCG /SOLAS
	Flare Upgrade (USCG/SOLAS Hand Held Locator Flares)
	Rescue Streamer™ High Visibility Ribbon (11" x 40')
First Aid Equipment	
	First Aid Kit (USCG) - Upgrade
	Multi-purpose Poly Bag (18" x 13" x 6 Mil)
Hypothermia Protection	
	Thermal Protection Aid - Reflective Blanket
	I2DF™ Inflatable Insulated Double Floor – 4 person
	I2DF™ Inflatable Insulated Double Floor – 6 person
	I2DF™ Inflatable Insulated Double Floor – 8 person
	I2DF™ Inflatable Insulated Double Floor – 10 person
	I2DF™ Inflatable Insulated Double Floor – 12 person
Miscellaneous Survival Supplies	
	Fishing Kit (USCG) - Upgrade
	Watermaker – Reverse Osmosis
	Playing Cards (Waterproof)
	Playing Cards (Waterproof)

WINSLOW® LifeRaft Company reserves the right to substitute comparable brands when necessary.

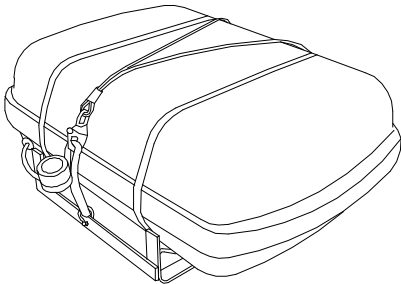

**USCG SPEC Low Profile Traditional Marine Canister, UV Inhibiting**  
 With Cradle & Hydrostatic Release As Shown Above: 25" x 34" x 14 1/2" (P/N 520)  
 Without Cradle: 25" x 34" x 12 1/2" (P/N 510)  
 With Cradle: 25" x 34" x 14 1/2" (P/N 500)

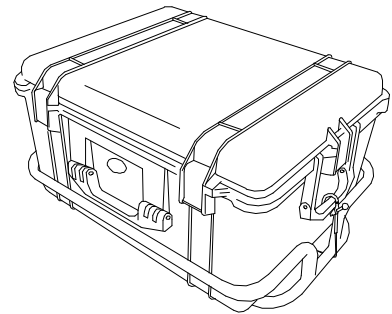

**WINSLOW® Pelican® Pac™ 4 or 6 Person Offshore**  
 With Cradle As Shown Above: 25" x 20 1/2" x 16 1/4" (P/N 440)  
 Without Cradle: 25" x 20" x 14" (P/N 430)



(800) 838-3012 ~ Fax (941) 613-6677  
**www.winslowliferaft.com ~ rafts@winslowliferaft.com**

IF THIS DOCUMENT HAS BEEN TRANSFERRED TO YOU ELECTRONICALLY, WINSLOW® RETAINS THE OFFICIAL RECORD. SUBSEQUENT ALTERATIONS WILL BE DISREGARDED. RATES SUBJECT TO CHANGE WITHOUT NOTICE.